

QHC Counting Scales

General Specifications

- | | |
|------------------|---|
| • Display | 20mm digit LCD display, with white LED backlight |
| • Capacities | 3kg~30kg |
| • Pan size | 230x300mm |
| • Keyboard | 20keys(Membrane keyboard) |
| • Housing | ABS plastic |
| • Max. Divisions | 3,000e; 2x3,000e; 30,000d; 60,000d |
| • ADC update | ≤ 1/10 second |
| • Operate Temp | -10°C~+40°C |
| • Power | AC adapter (12V/500mA), internal rechargeable battery (6V/4Ah) |
| • Gross weight | 5.1kg |
| • Packing | Master carton 4 in 1, gross weight 23.5kg, dimension 0.188 m ³ , 40 feet container can load 1100 machine, 20 feet container can load 550 machine |



- Responds quickly with accurate weights
- Battery provide up to 70 hours of continuous use(without backlight)
- OIML approval from NMI(approval no.:T7305)
- Counting method: 1. Sample 2. Enter unit weight
- Application: 1. Piece counting 2. Preset tare 3. Piece checking alarm
4. Accumulation 5. 10 unit weigh memory function
- Optional RS-232 interface: connect to computer, LP-50 label printer or TPuP mini printer
- Optional initial-verification



QHC Counting Scales

Model Name	Capacity	Readability	Division	Approx. weight	Approval
QHC-3K	3kg	0.1g	30,000d	5.1kg	CE
QHC-6K	6kg	0.2g	30,000d	5.1kg	CE
QHC-15K	15kg	0.5g	30,000d	5.1kg	CE
QHC-30K	30kg	1g	30,000d	5.1kg	CE
QHC+-3K	3kg	0.05g	60,000d	5.1kg	CE
QHC+-6K	6kg	0.1g	60,000d	5.1kg	CE
QHC+-15K	15kg	0.2g	60,000d	5.1kg	CE
QHC+-30K	30kg	0.5g	60,000d	5.1kg	CE
QHC-3K-M	3kg	1g	3,000e	5.1kg	CE, OIML
QHC-6K-M	6kg	2g	3,000e	5.1kg	CE, OIML
QHC-15K-M	15kg	5g	3,000e	5.1kg	CE, OIML
QHC-30K-M	30kg	10g	3,000e	5.1kg	CE, OIML
QHC-6K-MR	6kg	1g/2g	2x3,000e	5.1kg	CE, OIML
QHC-15K-MR	15kg	2g/5g	2x3,000e	5.1kg	CE, OIML
QHC-30K-MR	30kg	5g/10g	2x3,000e	5.1kg	CE, OIML

Options



Dimensions(mm)

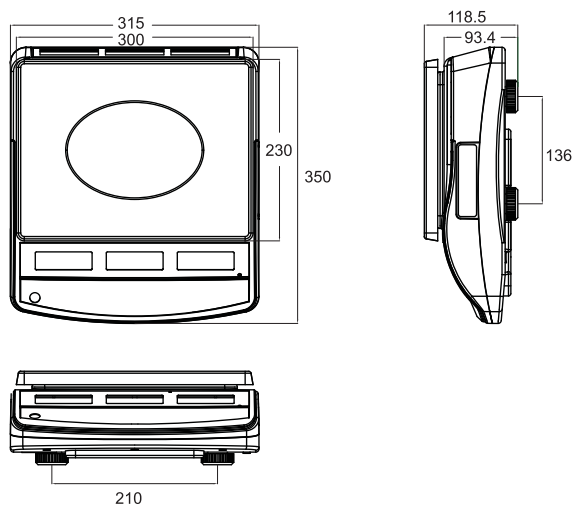

Print formats

