



TUNING-FORK BALANCE

SJ series

Accurate & Compact

- ▶ Quick response and accurate
- ▶ User friendly operation
- ▶ OIML (class II) approved



SJ-420E
(420g/0.01g)



SJ-6200E
(6200 g/0.1g)

**Newly developed MMTS
(Mono-Metal Tuning-fork Sensor)**

Not only does the tuning-fork sensor provide quick response and stability, but its newly developed MMTS also realizes a high resolution of 1/62,000.

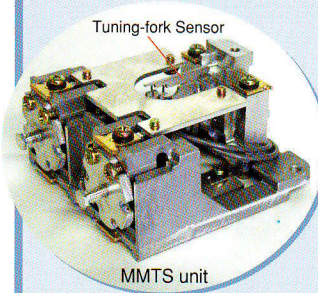

Patent pending

For further information, access www.vibra.co.jp



5-year warranty

MMTS is covered by a 5-year warranty that attests to its long-term stability and durability.

Comparator function

Users can tell at a glance whether a load is too heavy, too light, or the right weight according to the upper/lower weight limits they preset.



Bar graph display

A 20-step bar graph display readily indicates the current load's weight against the capacity.



Selectable modes and units

Users can select from 3 modes (weight, unit count, and percentage) and from 12 units of weight.

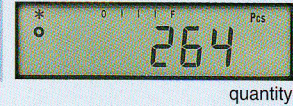
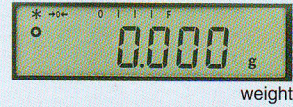

Weighing units

g, ct, oz, lb, ozt, dwt, GN, tI (Hong Kong), tI (Taiwan), tI (Singapore, Malaysia), momme, tola

Specifications

Model with EC approval*	SJ-220E SJ-220CE	SJ-420E SJ-420CE	SJ-620E SJ-620CE	SJ-1200E SJ-1200CE	SJ-2200E SJ-2200CE	SJ-4200E SJ-4200CE	SJ-6200E SJ-6200CE	SJ-12KE SJ-12KCE
Capacity	220g	420g	620g	1200g	2200g	4200g	6200g	12000g
Readability	0.01g	0.01g	0.01g	0.1g	0.1g	0.1g	0.1g	1g
Repeatability	±0.01g	±0.01g	±0.01g	±0.1g	±0.1g	±0.1g	±0.1g	±1g
Non-Linearity	±0.01g	±0.01g	±0.01g	±0.1g	±0.1g	±0.1g	±0.1g	±1g
Pan size	φ140mm			170×142mm	180×160mm			
Dimensions	235×182×75mm				265×192×87mm			
Weighing units ^{*1}	g, ct ^{*2} , oz, lb, ozt, dwt, GN ^{*3} , tI (Hong Kong), tI (Taiwan), tI (Singapore, Malaysia), momme, tola							
Power source	AC120/230V DC9V							
Output	RS-232C (option)							
Measuring system	Tuning-fork frequency sensing (MMTS)							
Tare	Full weighing range							
Calibration	With external weight							
Display	LCD (16.5mm high)							
Modes	weighing, counting, percentage							
Weight	Approx. 1.3kg				Approx. 2.7kg			

* SJ-XXXCE stands for EC approval models
 *1 only 5 units are available in SJ-XXXCE
 *2 carat is not available in SJ-6200CE and SJ-12KCE
 *3 GN is not available in SJ-12KE and SJ-XXXCE

Options & Peripherals

	SJ-220E~1200E SJ-220CE~1200CE	SJ-2200E~12KE SJ-2200CE~12KCE
Rechargeable battery	SJBT(S)	AJBT(M)
RS-232C	SJR(S)	SJR(M)
Relay contact	SJLM(S)	SJLM(M)
Under weighing hook	AJU(H)(S)	AJU(H)(M)
Satellite display	SDI/SDR	
Database software for Windows	RTS	

Dimensions (unit: mm)

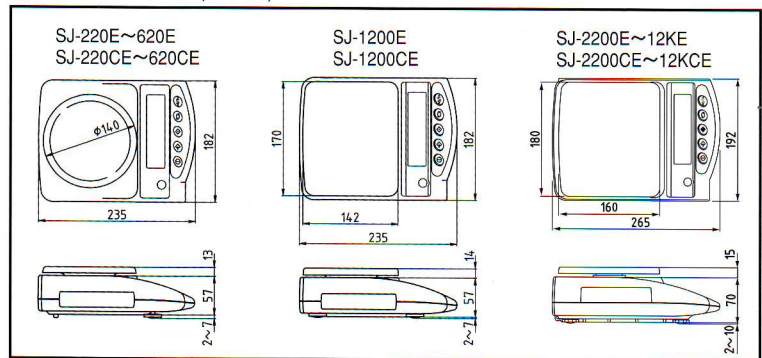

The contents of this catalogue are subject to change due to modifications and/or other reasons.

SHINKO DENSHI CO., LTD.

3-9-11 YUSHIMA, BUNKYO-KU, TOKYO 113-0034
 TEL : 81-3-3835-4577 FAX : 81-3-5818-6066
 URL : <http://www.vibra.co.jp> E-mail : shinko@vibra.co.jp

● Distributed by:

